



INSTRUCTION MANUAL



SS32 Model



SS64 Model



SS96 Model

SS Series Surgical Scrub Sinks

Installation - Operation - Maintenance - Cleaning



CAUTION

Read and understand all of the instructions and safety information in this manual before operating this product.

DESCRIPTION OF PRODUCT

This manual covers manual knee operated and Infrared self-activated Surgical Scrub Sink models -

- SS32 - single basin
- SS64 - double basin
- SS96 - triple basin

PURPOSE OF THIS MANUAL

This user manual details the installation, operation, maintenance and cleaning of the MAC Medical Surgical Scrub Sinks. This manual also contains general specifications, warnings and cautions.







Table of Contents

Warnings and Cautions Icon Key.....	3
General Specifications.....	4
In Line Flow Switch Timer Controller (S0130-01) - Specifications, Switch Rating and Wiring Diagram.....	5
<i>Switch Timer Controller Maintenance</i>	5
Sink Dimensions - SS32, SS64, SS96 Models.....	6
Installation.....	7
Installing and Operating the Soap Spout.....	8
Recommended Mounting Specifications - SS32 - Single Basin.....	9
Recommended Mounting Specifications - SS64 - Double Basin.....	10
Recommended Mounting Specifications - SS96 - Triple Basin.....	11
Connect Drain Pipe to Drain and Plumbing to Water Lines.....	12
<i>Plumbing Install Instructions</i>	12
<i>Preventative Maintenance</i>	13
<i>Troubleshooting</i>	13
Replacement Parts for Manual Knee Operated and Infrared Self-Activated Sink Plumbing.....	14
Plumbing Access (Manual Knee Operated Sinks Only).....	15
Infrared Controls (for Infrared Self-Activated Sinks Only).....	15
<i>Installation</i>	15
<i>Operation</i>	15
Instructions for Cleaning Stainless Steel Surgical Scrub Sinks.....	16
Optional IR Timer Assembly.....	17
<i>Installing Optional Electronic Sink Timer Display</i>	17
Timer Operation Display and Programming.....	18
<i>Timer Battery Replacement</i>	19
In-line Wall Carrier Mount Assembly - Single Basin Sinks (Part #S0001).....	20
In-line Wall Carrier Mount Assembly - Dual Basin Sinks (Part #S0002).....	21
In-line Wall Carrier Mount Assembly - Triple Basin Sinks (Part #S0003).....	22
Limited Lifetime Warranty.....	24

KEEP THIS MANUAL

Warnings and Cautions Icon Key

The following is a list identifying the various warning and caution icons used in this manual.

Icon Type	Icon	Description
Warnings		(Red triangle with an exclamation point) indicates the potential for minor to severe injuries up to and including death to personnel.
Cautions		(Yellow triangle with an exclamation point) indicates the potential for minor injury to personnel and damage to equipment.
		Note: The exclamation point will not be visible where only equipment damage is present.
Burn Hazard Warnings		(Yellow triangle with radiating lines) indicates a potential burn injury to personnel.
Electrical Warnings		(Yellow triangle with a lightning bolt) indicates a possible shock hazard is present.
		Severe shock hazards shall be a lightning bolt in a red triangle.

Warnings and Cautions When Installing or Operating This Product

Prior to installation or operation, the user must read these warnings and cautions.

The following is a list of the safety precautions that must be observed when operating this equipment.



WARNING - INJURY HAZARD -

REPAIRS AND ADJUSTMENTS should be attempted only by experienced service agents fully acquainted with this equipment. The use of inexperienced, unqualified persons to service the equipment, or the installation of unauthorized parts, could cause serious personal injury, or result in costly damage. Always unplug power cord from power source prior to attempting any repairs or servicing.



WARNING - Burn Hazard

DO NOT CHANGE temperature settings on thermostatic mixing valve, unless you are a trained mechanic. ANY REPAIR or modification of mixing valve may affect the high temperature setting. The installer must check operating temperature before sink is back in operation.



CAUTION - POSSIBLE EQUIPMENT DAMAGE -

When cleaning the sink - see complete Cleaning Instructions in this manual.

NOTE: This product is to be used strictly for the purpose it was designed for. If this product is used in a manner not specified by MAC Medical, the protection provided by the equipment may be impaired. MAC Medical disclaims all liability for the consequences of this product being used for purposes other than its intended design. Product modification or misuse can be dangerous. MAC Medical disclaims all liability for the consequences of product alterations or modifications, as well as for the consequences which might result from the combination of this product with other products, whether supplied by MAC Medical or by or by other manufacturers, unless such a combination has been specifically endorsed by MAC Medical.

General Specifications

1. **Material:**

- a. Sink basin and sink top: 14 gauge, 300 series stainless steel
- b. Sink skirt: 18 gauge, 300 series stainless steel.

2. **Plumbing Material**

- a. 1/2" copper or brass pipe
- b. Sink is furnished with in-line check valves on supply lines.

3. **Utility requirements:**

- a. Cold water - 20 to 50 psig 70°F max
- b. Hot water - 20 to 50 psig 120°F to 140°F
- c. Water lines should be flushed clean before water connections are made.
- d. **It shall be the customers responsibility:**
 - to ensure by use of pressure regulators or other means, that maximum specified pressures are not exceeded.
 - to ensure that water supplies are properly protected for internal cross connection control in accordance with local building and plumbing requirements.
 - to eliminate water hammer conditions should they occur in the service piping.

4. **Power requirements (for sinks with optional infrared sensor operations)**

- a. 120 Volt, 60 Hz, single phase, 3.0 amp GFCI protected electrical outlet (by others)
- b. 220 VAC, 60 Hz, single phase 1.5 amp
- c. to be installed per local building codes.

5. **Sink Weight**

- a. Single basin - 130 lb
- b. Double basin - 230 lb
- c. Triple basin - 320 lb

6. **Sink Certifications**

- a. UL and cUL certified
- b. California OSHPD pre-approved when mounted on a structurally sound wall.

7. **Mixing Valve Specifications**

- a. Connections - 1/2" NPT Inlets and 1/2" NPT Top Outlet
- b. Capacity (without checkstops) - 5.25 gpm [19.9 L/min - at 45 psi differential (310 kPa) with hot water supply between 140° - 180°F (60° - 82°C) and 50/50 mix}] - (±0.25 gpm [0.95 L/min])
- c. Maximum Hot Water supply Temperature - 190°F (88°C)
- d. Minimum Hot water supply temperature (not applicable to low temperature hot water valves - 5°F (2.8°C) above set point
- e. Temperature Ranges - ASSE 1016 Type T: 65-115°F (18-46°C); ASSE 1016 Type T/P: 90-110°F (32-43°C)
- f. Maximum Operating Pressure - 125 psig (862 kPa)
- g. Maximum Static Pressure - 125 psig (862 kPa)
- h. Compliant - ASSE 1016-T-P
- i. Certified - CSA B125

InLine Flow Switch Timer Controller (S0130-01) Specifications, Switch Rating and Wiring Diagram

NOTE: This feature (Fig. 1) is available only on Infrared Activated Scrub Sinks.

This is an explosion-proof brass flow switch, actuation set point 0.50 GPM (1.89 LPM), and calibrated for water at standard conditions. It is used for accurate detection of excessive or insufficient flow rates.

Service	Compatible liquids
Wetted materials	Housing: brass; Piston: polysulfone; Spring: 316SS; O-Ring: Fluoroelastomer, Other: Epoxy
Temperature Limits	-20 to 225°F (-29 to 107°C)
Pressure Limits	1000 psig (68.9 bar)
Accuracy	±10% of set point
Repeatability	±1%
Switch Type*	SPDT, 20 VA
Electrical Rating	.17 A @ 120 VAC, .08 A @ 240 VAC, .13 A @ 120 VDC, .06 A @ 240 VDC
Electrical Connection	18 AWG, 24" (60.96 cm), Polymeric lead wires
Process Connection	1/4" female NPT
Mounting Orientation	Any position. Set points shown are based on vertical, inlet down position.
Required Filtration	50 microns or better
Weight	0.66 lb (301 g)
Agency Approval	CE

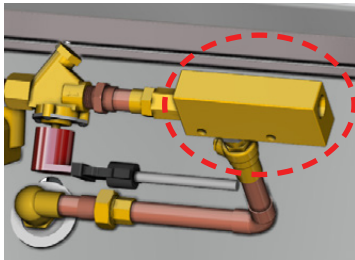
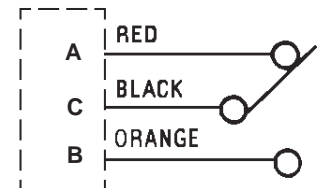

Fig. 1: In-line Flow Timer Controller

*Switch Ratings Max Resistive Load

VA	Volts	Amps AC	Amps DC
20	0-30	.4	.3
	120	.17	.13
	240	.08	.06

Typical Wiring Diagram



Pin Connections for Units with MS Receptacle

This unit was calibrated in a vertical position, with lead wires up. Install unit in piping system, using standard pipe fitting procedures. Be sure to keep thread sealing compound out of unit. Make sure that flow is in proper direction - marked "IN" and "OUT" on housing. See wiring diagrams for electrical connections.

CAUTION: See "Switch Ratings" before connecting power.

CAUTION: Flow settings for this switch is normally calibrated using water @ +70°F on increasing flow. Water-calibrated units are not recommended for air/gas applications.

Switch Timer Controller Maintenance

Accumulation of foreign debris should periodically be removed from these switches. Occasional "wipe-down" cleaning when excessive contamination is present is all that is normally required.

To Clean: Remove unit from system and disassemble as shown at right. Clean all parts, reassemble and reinstall unit.

Note: 50 micron filtration is recommended.

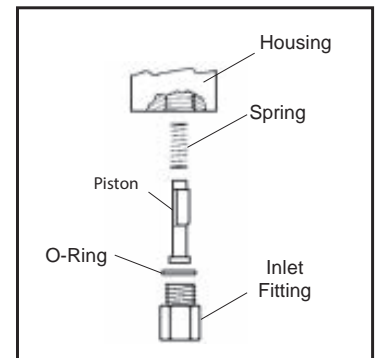

Sink Dimensions - SS32, SS64, SS96 Models

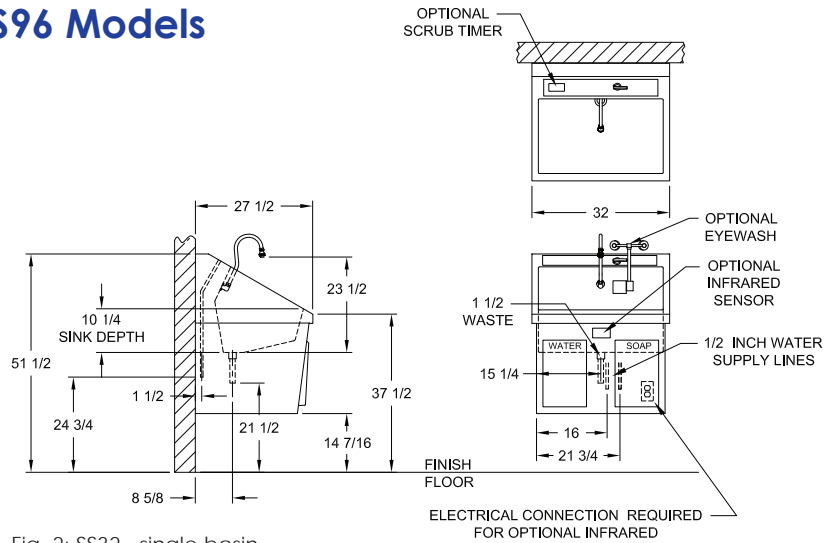

Fig. 2: SS32 - single basin

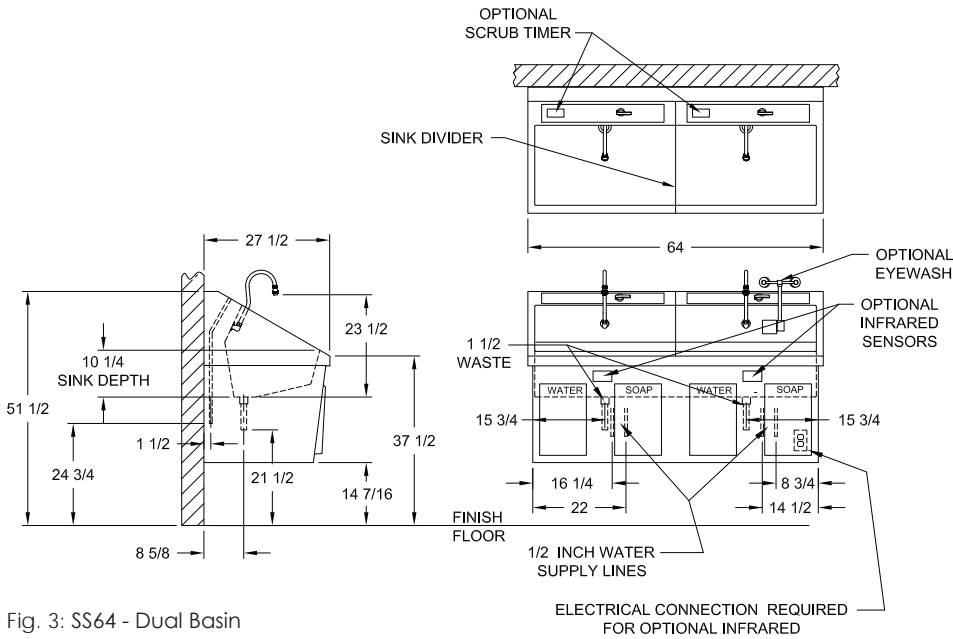

Fig. 3: SS64 - Dual Basin

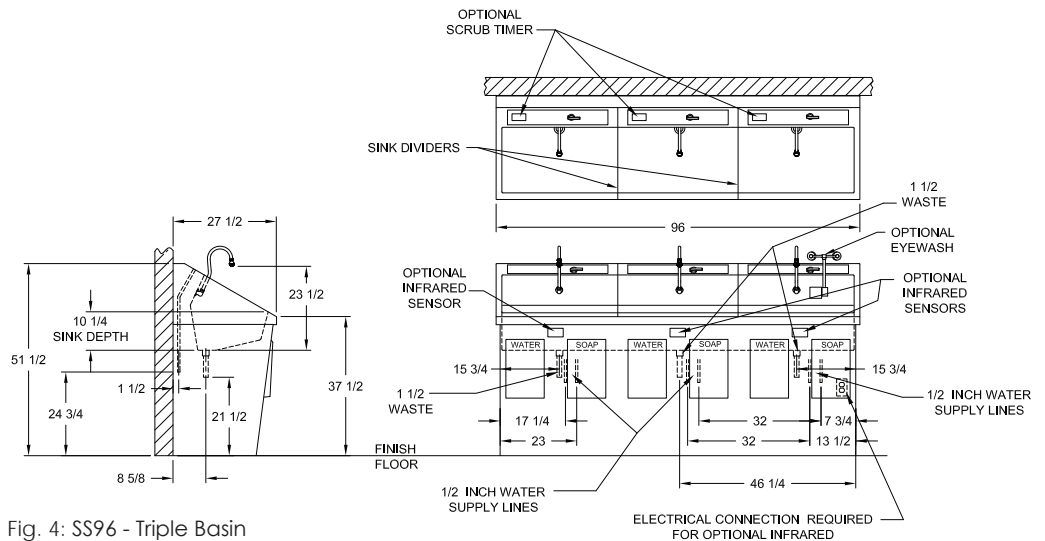



Fig. 4: SS96 - Triple Basin

Installation

1. Carefully uncrate the scrub sink. The mounting hardware is under the sink, secured to the shipping materials. Be sure to remove all hardware before discarding packaging.
2. Check water supply and waste terminal locations -
 - A. Be sure all connections are safely accessible to the sink and in proper working condition. NOTE: For proper sink operation the hot water temperature must be 120°F.
 - B. Install sink near a hot water source.
3. Locate Infrared sensor activated sinks near a 110/120V outlet power source.
4. Attach wall mount sink support brackets to the wall.
 - A. "Z" Brackets for mounting the sink to the wall come with the sink (Fig. 5). Recommended mounting specifications for Z Brackets are shown in Fig. 13 (SS32), Fig. 16 (SS64), and Fig. 19 (SS96) on page 9 through page 11.
 - B.  **IMPORTANT:** For wall mounted units, the wall structure must be capable of supporting the load.
 - C. Optional wall mounting systems (in-wall chair carrier and pedestal style) and their mounting specifications are shown in Fig. 15 (part S0001 for sink SS32), Fig. 18 (part S0002 for sink SS64), and Fig. 21 (part S0003 for sink SS96) on page 9 through page 11.
5. Install the soap spout on the sink (see page 8).
6. Mount the sink body onto the Z Brackets that were attached to the wall.
 - A. With the help of an assistant, slide the sink over the Z Brackets until it locks securely into place (Fig. 6 - Fig. 7, Z brackets shown in green).
7. Connect the drain pipe to the drain
8. Connect the water supply to the plumbing (page 12).

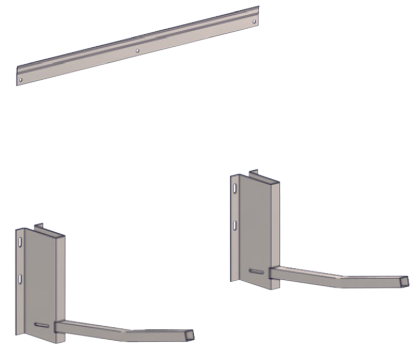

Fig. 5: Z brackets

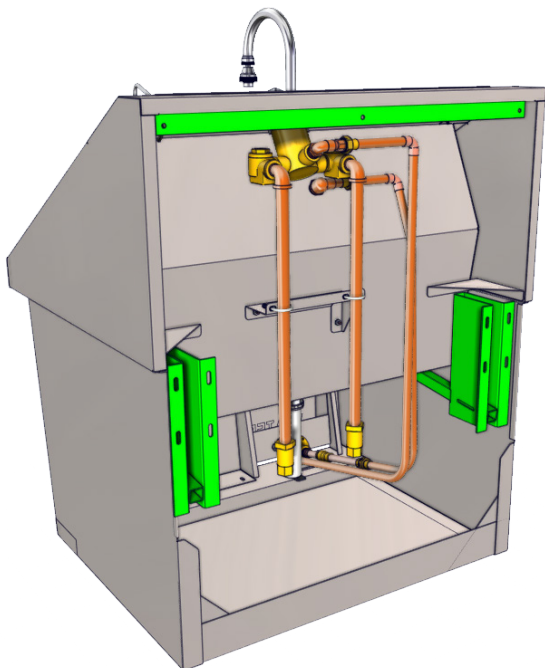

Fig. 6: Z brackets on sink

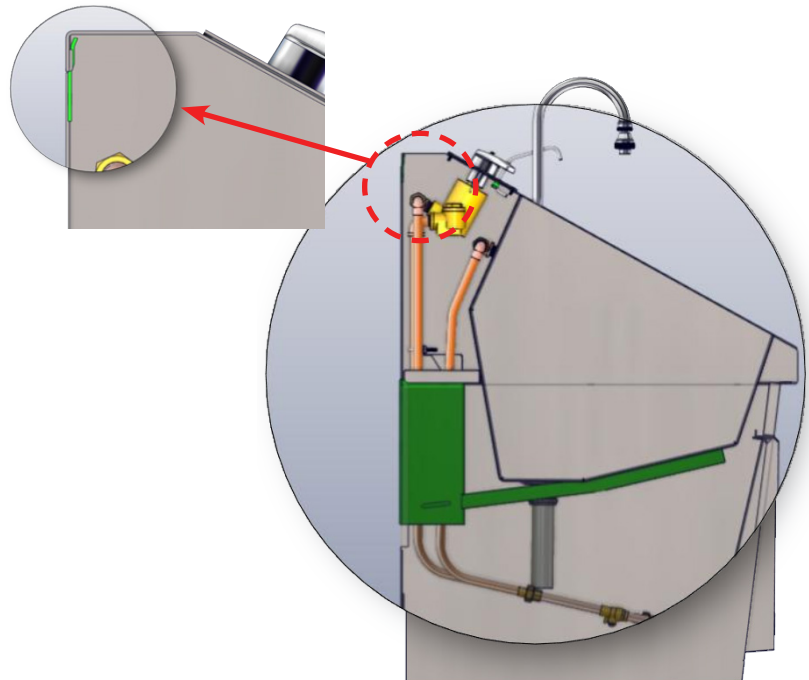

Fig. 7: Cross section showing Z bracket on sink

Installing and Operating the Soap Spout

To prevent damage during shipment, the soap dispenser is stored inside the sink basin. Soap Dispenser tubing is also included. The dispenser spout should be installed before hanging the sink.

1. To install - remove the bushing (Fig. 8 - Item 3 shown in green).
2. Feed the spout (item 1) through the small hole at the top of the sink (Fig. 9). The nut (item 2) should rest on top of the sink.
3. Reinstall the bushing onto the spout from inside the cabinet (Fig. 10).
4. Attach the soap tubing to the spout and soap pump (circled in red) as shown in Fig. 11 and Fig. 12.

To Operate the Soap Pump - press the soap spout down repeatedly to start the flow of the soap.

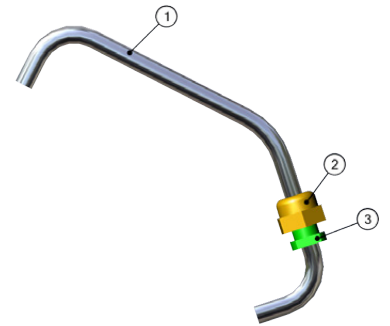

Fig. 8: Soap Spout with nut and bushing



Fig. 9: Install Soap Spout

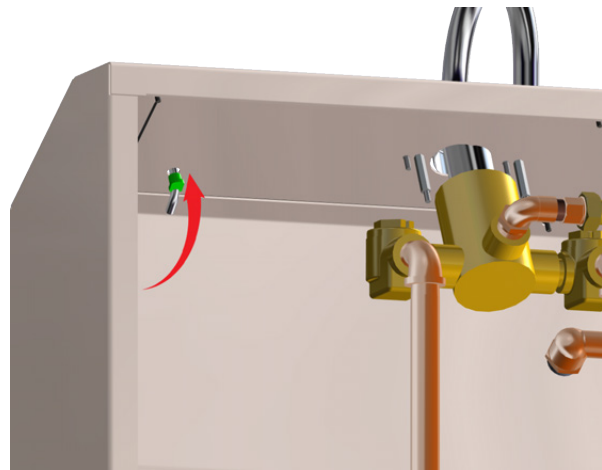

Fig. 10: Secure spout with bushing



Fig. 11: Install soap dispenser tubing

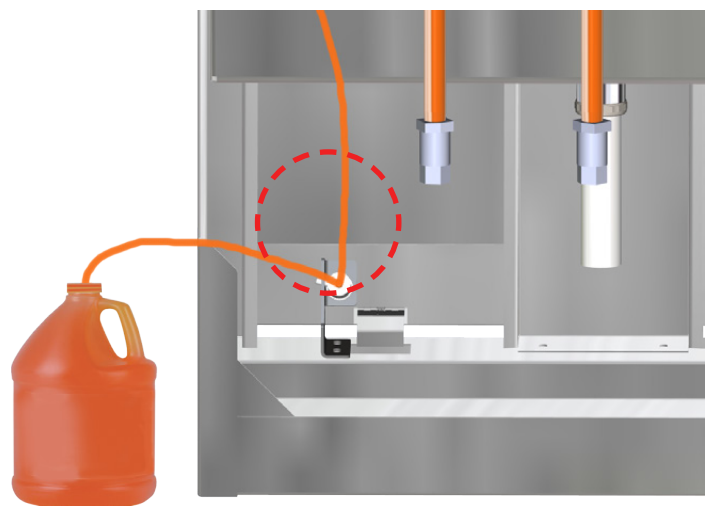

Fig. 12: Close-up of soap pump with tubing attached

Recommended Mounting Specifications - SS32 - Single Basin

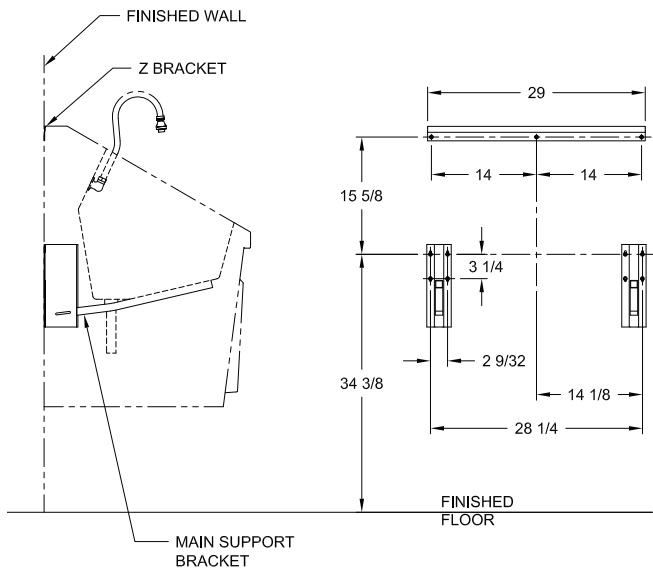

Fig. 13: Z bracket mounting locations - SS32



Fig. 14: In-line wall carrier mount - S0001

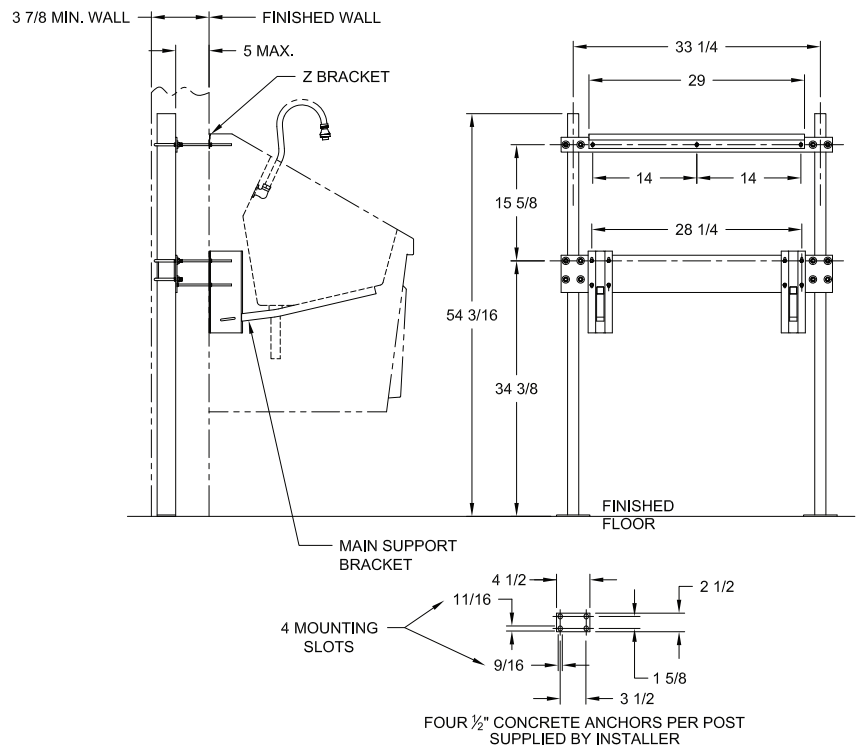

Fig. 15: In-line wall carrier mounting locations - SS32

For the assembly drawing of In-line wall carrier mount (S0001), see page 20.

Recommended Mounting Specifications - SS64 - Double Basin

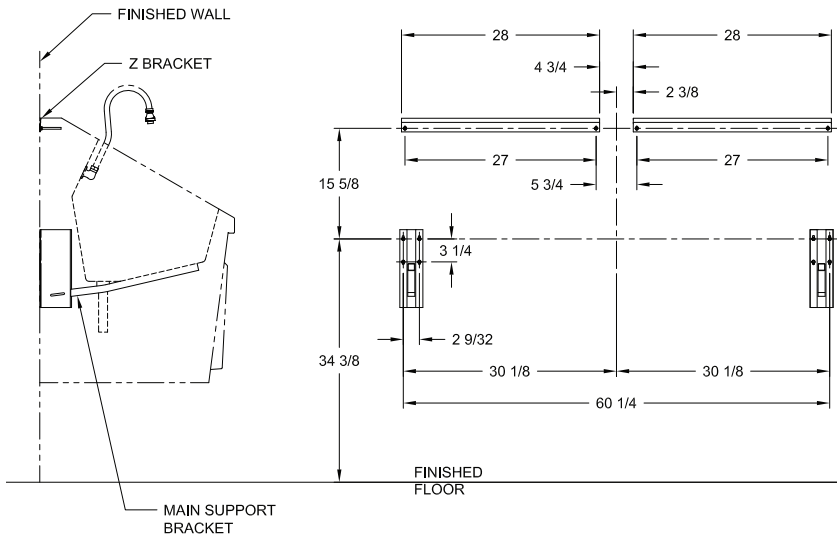

Fig. 16: Z bracket mounting locations - SS64



Fig. 17: In-line wall carrier mount - S0002

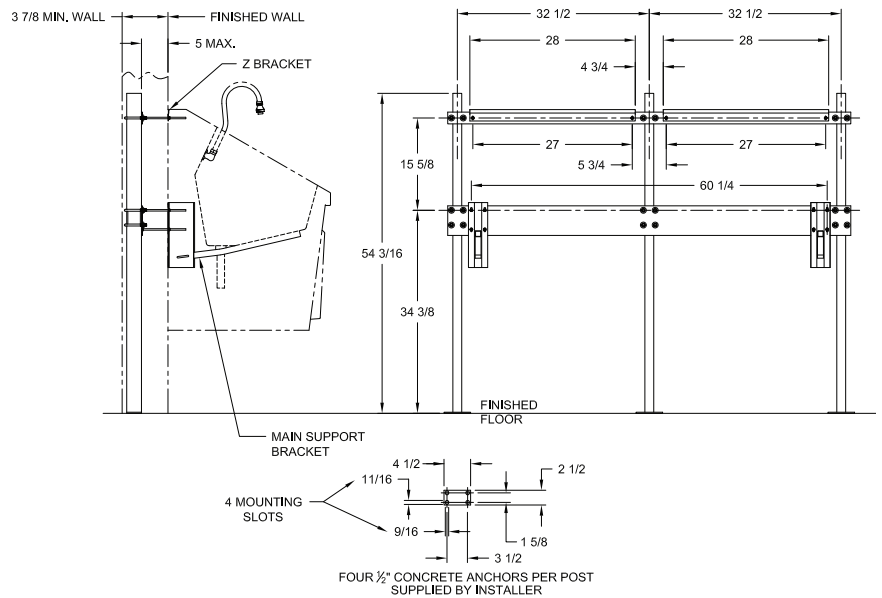

Fig. 18: In-line wall carrier mounting locations - SS64

For the assembly drawing for the In-line Wall Carrier Mount (S0002), see page 21.

Recommended Mounting Specifications - SS96 - Triple Basin

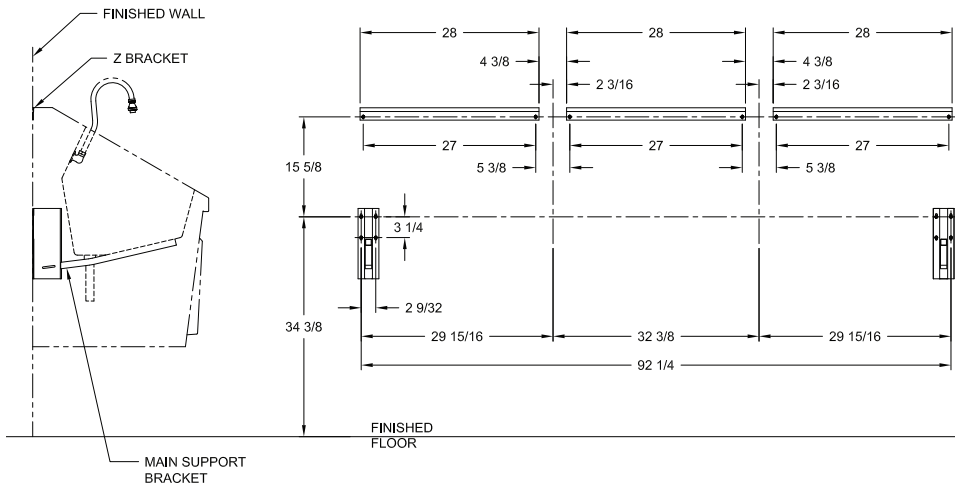

Fig. 19: Z bracket mount locations - SS96

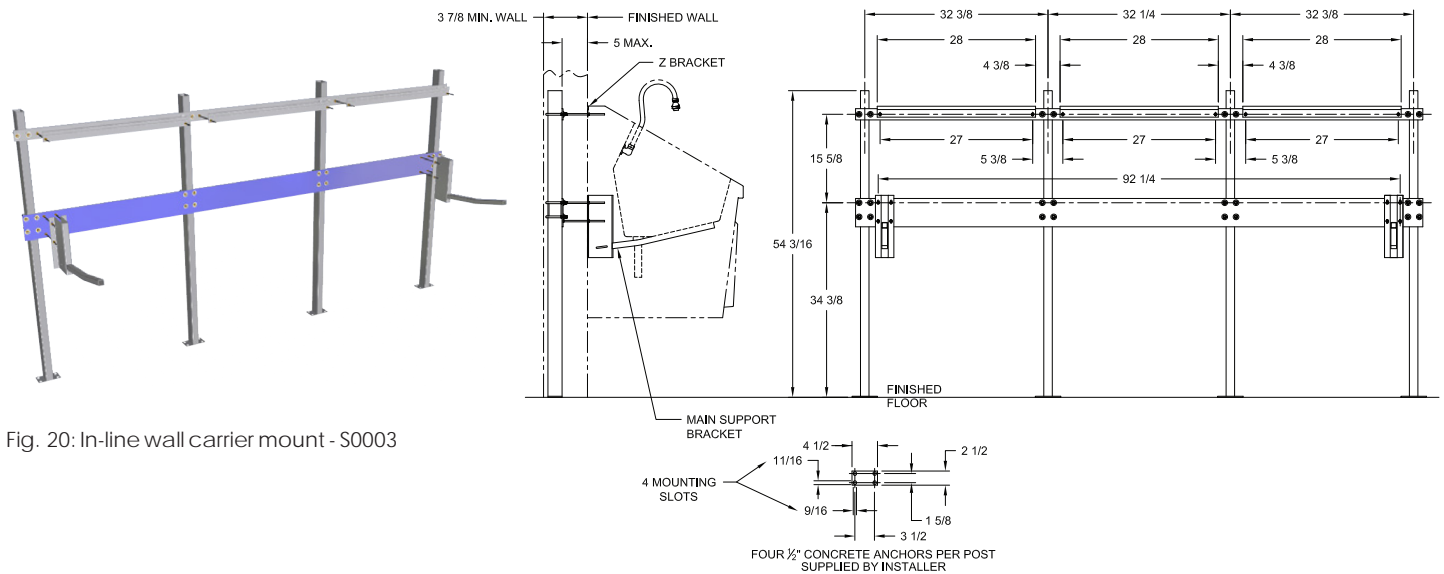



Fig. 20: In-line wall carrier mount - S0003

Fig. 21: In-line wall carrier mounting locations - SS96

For the assembly drawing of the In-Line Wall Carrier Mount (S0003), see page 22.

Connect Drain Pipe to Drain and Plumbing to Water Lines

 Local building or plumbing codes may require modifications to the information provided. You are required to consult the local building and plumbing codes prior to installation. If the information provided here is not consistent with local building or plumbing codes, the local codes should be followed. This product must be installed by a licensed contractor in accordance with local codes and ordinances.

 FAILURE TO COMPLY WITH PROPER INSTALLATION AND MAINTENANCE INSTRUCTIONS COULD CONTRIBUTE TO VALVE FAILURE.

This hot water master tempering valve cannot be used for tempering water temperature at fixtures. Severe bodily injury (i.e., scalding or chilling) and/or death may result depending upon system water pressure changes and/or supply water temperature changes. ASSE standard 1016, 1069 or 1070 listed devices should be used at fixtures to prevent possible injury.

This hot water tempering valve is designed to be installed at or near the boiler or water heater. They are not designed to compensate for system pressure fluctuations and should not be used where ASSE standard 1016, 1069 or 1070 devices are required. These valves should never be used to provide "anti-scald" or "anti-chill" service.

The components of the system must be of materials with a construction capable of withstanding the high limit output temperatures of the water heating source.

 **Need for Periodic Inspection and Yearly Maintenance:** Periodic inspection and yearly maintenance by a licensed contractor is required. Corrosive water conditions, temperatures over 200°F, unauthorized adjustments or repair could render the valve ineffective for service intended. Regular checking and cleaning of the valve's internal components and check stops help ensure maximum life and proper product function. Frequency of cleaning and inspection depends upon local water conditions.

Plumbing Install Instructions

Plumbing Installation should be in accordance with accepted plumbing practices. Installation and field adjustment are the responsibility of the installer.

1. Flush all pipes thoroughly before installation.
2. Connect sink drain pipe to drain connection.
3. Close both hot and cold water shutoff valves upstream of the tempering valve.
4. Bleed pressure from the system.
5. Route copper tubing or piping to fit valve dimensions.
6. Remove tailpieces from the valve and make sure union nuts are over the tubing/piping before connecting to the tailpiece.
 - A. Note: If soldering, remove unions and gaskets from valve body prior to soldering to prevent damage to valve from excessive heat.
7. Flush piping again, install valve using filter gasket on hot and cold water inlets and fiber gasket on mixed water outlet.
8. Turn on the cold and hot water. If any leaks are observed, tighten connections as necessary to stop leaks before proceeding.
9. After the plumbing installation is complete, the water pressure can be adjust to avoid excess splash. The pressure can be controlled by adjusting the flow with the flow control valve. See item #4 of the plumbing diagram for the manual knee operated plumbing on page 14.

Preventative Maintenance

Every 6 months -

1. Check and adjust the temperature setting.

Every 12 months -

1. Shut off water supply
2. Open up checkstops.
3. Clean strainers and check for free movement of checkstop poppet.
4. Replace seals if cracked, cut, or worn.
5. Reassemble.
6. Adjust stem to desired temperature.

Troubleshooting

1. If the flow of water is less than desired –
 - A. Valves upstream from supply not fully open
 - B. Low supply pressures
 - C. Accumulation of lime deposits in hot water pipes, restricting the flow of water
 - D. Checkstops not fully open
 - E. Clogged strainer screens in the checkstops
 - F. Clogged cartridge
2. Flow of water is completely cut off –
 - A. Valves upstream from supply completely closed
 - B. Failure of cold water supply pressure (mixing valve is designed to shut off on a cold water supply failure)
 - C. Checkstops completely closed
3. Flow is untempered hot or cold water –
 - A. Accumulation of lime deposits in hot water pipes, restricting the flow of hot water
 - B. Thermostatic actuator failure; replace with new thermostatic actuator
 - C. Hot and cold water supplies are connected to the wrong ports
4. Maximum temperature specified for the mixing valve cannot be obtained –
 - A. Accumulation of lime deposits in hot water pipes restricting the flow of hot water
 - B. Hot water supply temperature is too low
5. Variable discharge temperature occurs –
 - A. Extreme pressure variations in supply lines
 - B. Valve operating below minimum capacity requirements

Replacement Parts for Manual Knee Operated and Infrared Self-Activated Sink Plumbing

Both plumbing configurations shown below indicate which parts are replaceable. See table below for replacement part numbers.

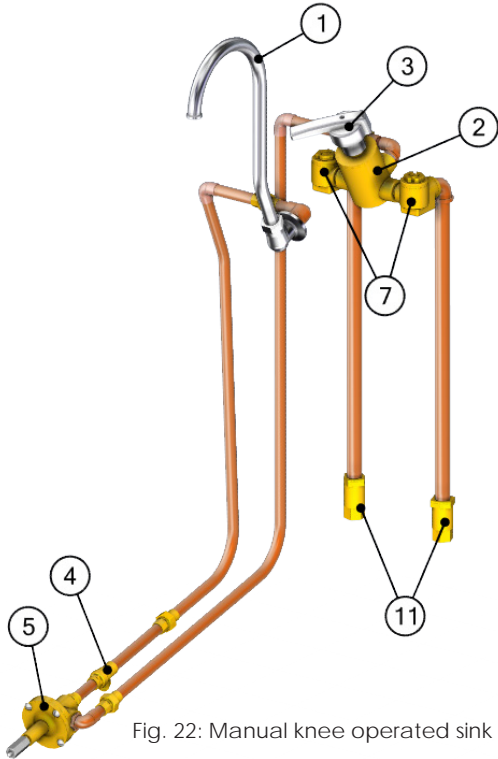

Fig. 22: Manual knee operated sink plumbing

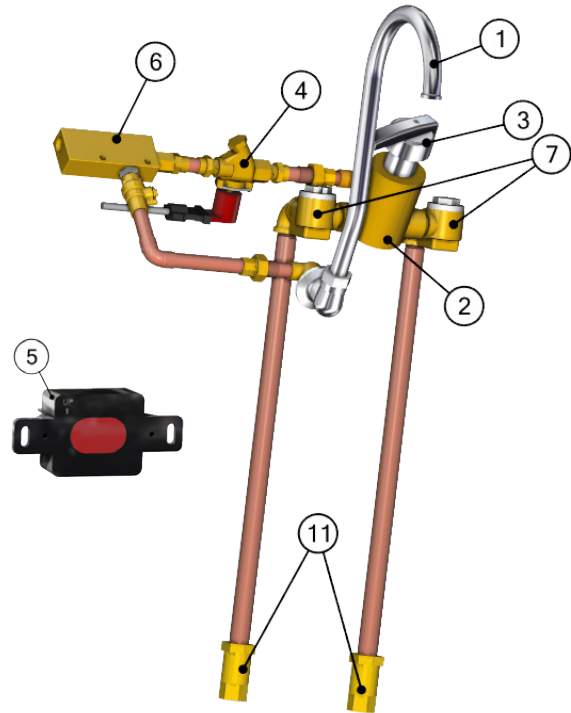
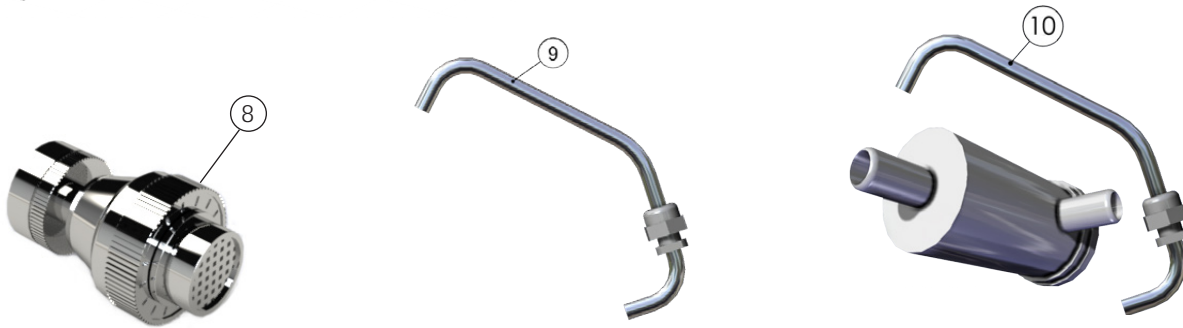

Fig. 23: Infrared Self-Activated Sink Plumbing



Item #	Description	Knee Operated	Part #	Infrared Activated	Part #
1	Spout	for both knee operated or infrared activated plumbing			SS0132-01
2	Thermostatic Mixing Valve	for both knee operated or infrared activated plumbing			S0009
3	Mixing Valve Handle	for both knee operated or infrared activated plumbing			S0010
4		1/2" Balance Flow Control Valve	S0024	Solenoid Valve (for Infrared)	S0013
5		Knee Operated Water Valve	S0029	Infrared Sensor	S0012
6	Inline Flow Switch Timer	for infrared activated plumbing			S0130-01
7	Checkstop Strainer (L/R)	for both knee operated or infrared activated plumbing			S0011
8	Swivel Aerator	for both knee operated or infrared activated plumbing			S0032
9	Soap Spout	for both knee operated or infrared activated plumbing			S0041
10	Soap Pump Kit	for both knee operated or infrared activated plumbing			S0028
11	Check Valve	for both knee operated or infrared activated plumbing			S0131
12	Sink Dividers (not shown)	for dual and triple basin sinks			S0034

Plumbing Access (Manual Knee Operated Sinks Only)

1. Open the knee panel door by depressing the latch at the bottom of the panel door (Fig. 24).
2. Swing the door fully open to access the hinges (Fig. 25).
3. Push the hinge pins inward to release the door from the hinges (Fig. 26).

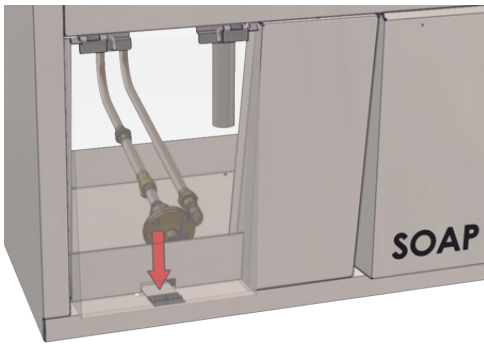

Fig. 24: Push down knee panel door latch

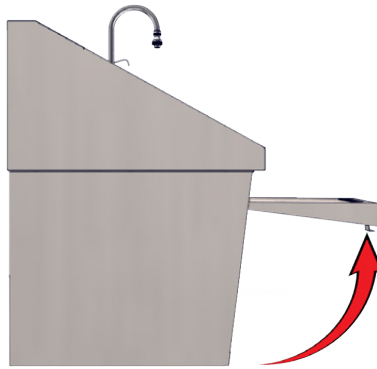

Fig. 25: Door in fully opened position

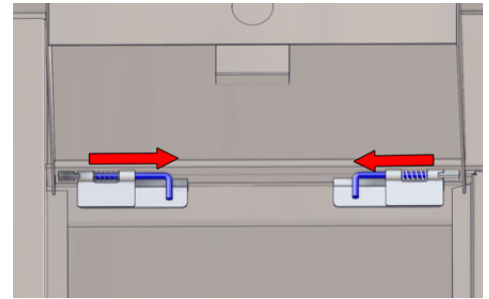

Fig. 26: Push hinges inward

4. To reattach the door, push in the hinge pins and fit the top corners of the knee panel door onto the left and right hinge leaves (Fig. 27 - circled in red). When the door is refitted, release the hinge pins to secure the door to the sink.
5. The knee panel door should rotate freely on its hinges. Rotate the door back down on its bottom latch to close it (Fig. 28).

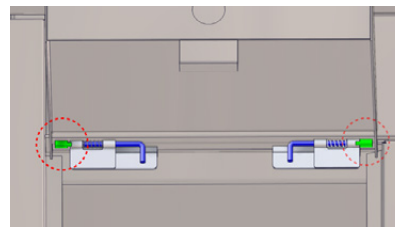

Fig. 27: Left - right hinge leaves

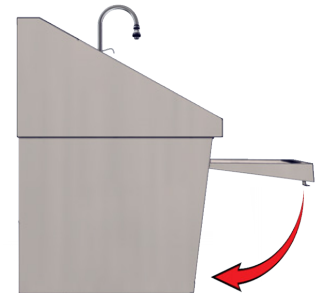

Fig. 28: Door should rotate freely on hinges

Infrared Controls (for Infrared Self-Activated Sinks only)

Installation

The sinks are supplied with a 24V power transformer(s) that connects to a standard duplex outlet (110/120V outlet required).

Single basin sinks have one sensor, dual basin sinks have two sensors (one for each basin) and triple basin sinks have three sensors (one for each basin).

1. Plug the transformer(s) into the outlet.
2. A red LED will flash in the sensor window (Fig. 29 - circled in red).
 - A. **Important:** Do not interrupt the sensor beam until the light turns off.

Operation

The sensors are pre-set and equipped with a logic board. The sensors determine the range during initialization period. (The time after initial power until the light turns off is approximately 5 minutes.) The range is approximately 12-14" in front of the sensor and is 25 degrees at peak.

During the initialization period, the sensors allow for fixed objects that may be within the sensors' range. The sensors are equipped with a 2 second on/off delay, and no-time-out feature. This prevents the sink from turning on when walking past at a normal pace and no-time-out allows for an uninterrupted scrub.





Fig. 29: Location of infrared sensor

Instructions for Cleaning Stainless Steel Surgical Scrub Sinks

Stainless steel sinks must be cleaned on a regular basis to prevent any unnecessary damage to the stainless steel surfaces.

When cleaning Stainless steel sinks, make sure to use the proper approved cleaning agents and cleaning materials.

 CAUTION DO NOT USE these Cleaning Materials	 CAUTION DO NOT USE these Cleaning Agents
Abrasive Pads	Hard Water (water with a pH reading above 7.0)
Scrapers	Hydrochloric Acid
Steel Wool	Steam or high pressure water
Wire Brushes	Bleach or any compounds containing chlorine or Sodium hypochlorate, or ammonium chloride salts.

Approved cleaning materials and agents

- Soft, clean lint-free cloth
- Non-abrasive cleaning pads
- Soft bristle brush
- Mild detergents
- Sodium Bicarbonate (baking soda)
- Distilled water (pH rating 7) alone or with a mild detergent
- White vinegar (in a spray bottle)
- Isopropyl Alcohol
- Hospital-grade non-bleach disinfectants
- Cleaners approved for use on stainless steel

Cleaning Stainless Steel Surfaces

1. Using a damp, lint-free cloth and approved cleaner, wipe down the entire exterior surface of the stainless steel sinks. Using a damp, lint-free cloth with distilled water and a mild detergent, wipe down the entire exterior surface of the stainless steel sinks.
2. Let cleaned sinks air dry.

Cleaning Decals or Printed Labels

- Use only distilled water and a mild detergent applied with a clean, dry lint-free cloth to clean decals or printed labels.
- Cleaning agents can remove or smear any printing from decals and print labels.
- Cleaning agents can damage plastic materials used in manufacturing covers for electronic items such as infrared sensor face.

Optional IR Timer Assembly

An electronic IR Timer Assembly (S0202-SST-KT) can be purchased and installed on Infrared Activated surgical scrub sinks.

The installation requires some modification of the sink top in order to install.



Fig. 30: IR Timer Assembly for IR scrub sinks

Installing Optional Electronic Sink Timer Display

1. To mount the timer housing on the sink top, drill three holes using the hole dimension sizes and locations as shown in Figure 31. Two holes are for mounting the timer housing, one for threading the three flow-switch timer wires to the top side for connection to the timer read-out.
2. Place a grommet in the 0.38 diameter wire threading hole. (Grommet to be supplied by others.)
3. Mount the timer housing to the top of the sink in the 0.31 diameter drilled holes. Mounting studs (0.25 diameter) are provided on the housing. Secure to sink top with the provided hex nuts.
4. Thread the three flow-switch timer wires through the drilled hole on top of the sink (Fig. 32 - circled in red).
5. Connect the three timer wires (black, red and orange) to the timer read-out terminal connections as shown in Fig. 33.
6. Program the timer as shown on page 18.

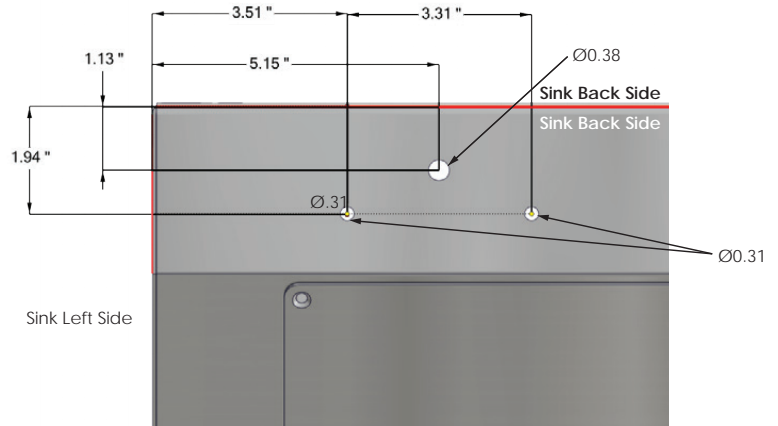

Fig. 31: Drill locations on sink top

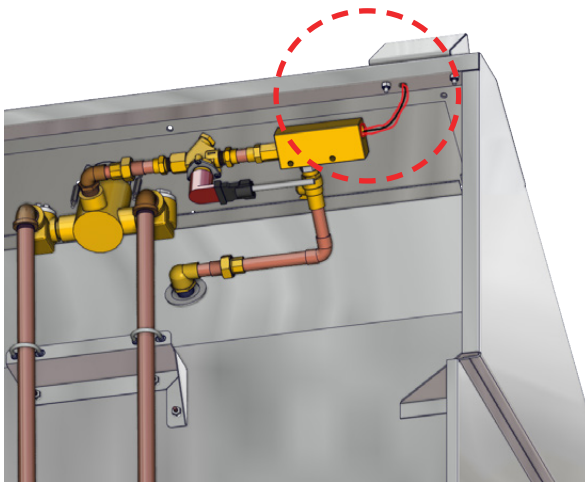

Fig. 32: Thread wires thru grommet hole

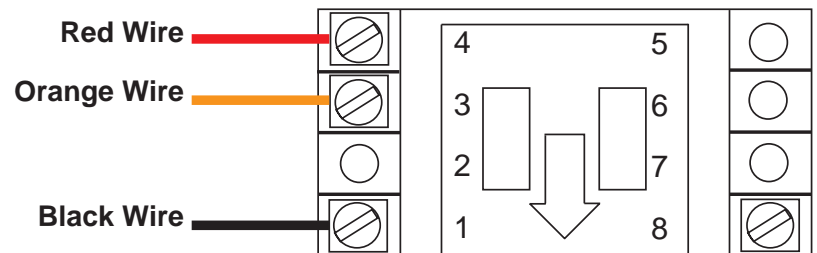
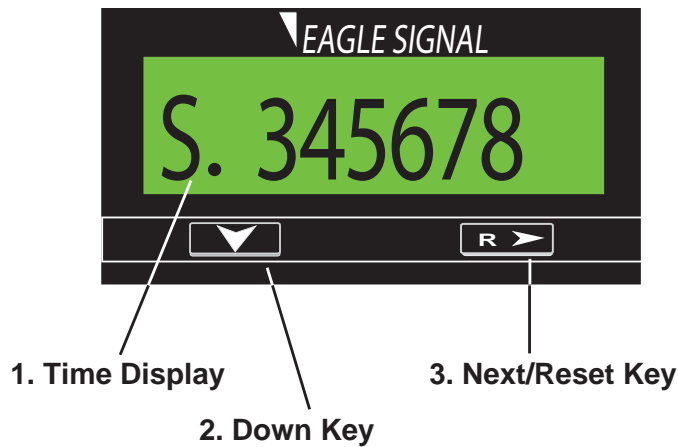

Fig. 33: Wiring diagram for timer

Timer Operation Display and Programming



Time Display: Accumulates time when the timing start input is active. Timing will not take place when the external or front panel reset is active. The leftmost digit is the time value legend.

Down Key: When the program input is active, this key is used to scroll through the menu items. After a menu item has been chosen for editing, the down key is used to set the value for the currently selected (flashing) digit.

Next/Reset Key: Resets the accumulated time if Front Panel Reset is enabled in Programming Mode. When the program input is active this key is used to select a menu item for editing (leftmost digit will begin to flash) and then move to the desired digit to be changed.

Programming -

Programming parameters can be accessed, when the Program Enable input is active, by pressing the Down key. To edit a parameter use the Down key to scroll until the desired parameter appears on the screen. Pressing the Next key will cause the leftmost digit of that value to begin to flash. Use the Next and Down keys in combination to choose individual digits and change their value.



Front Panel Reset Enable: When active (ON) the time value, when being displayed, can be reset by pressing the Next/Reset key. If set to OFF, the time value can only be reset through the remote input.



Time Format: Sets the units in which the elapsed time will be accumulated. Use the next key to scroll through the available choices: Seconds, Minutes (_ _ _ _ . _), Hours (_ _ _ _ . _), Hours: Minutes: Seconds.

Note: On initial start-up, as well as after any programming changes, it is necessary to reset the unit before beginning operation

Timer (S0050) - Specifications and Terminal Connections

The timer is an Elapsed Time Indicator that is powered by an internal 3-volt lithium battery. It comes pre-assembled in its housing and ready for mounting to the sink.

Specification	Description
Start/Stop Input	NPN, Contact Closure; Accumulates time when connected to common; Low State: < 1.0 VDC, High State: > 2.0 VDC (28VDC max)
Security Input	Allows access to panel reset and programming features
Remote Reset Input	NPN or Contact Closure to common; level sensitive
Power Source	Single or dual 3V Lithium battery; typical 5 years life w/single battery, 10 years w/dual batteries
Ranges & Resolution	Seconds, minutes to 1/10, hours to 1/10, hours: minutes: seconds
Display	12 mm high, Supertwist LCD; 7 digits; "Low Bat" indicator
Backlighting	Green Illumination over whole viewable area. Requires 10 to 28 VDC power source
Dimensions & Mounting	See dimensions picture below. Panel Mount with supplied mounting bracket and gasket
Connections	Screw terminals
Weight	Approximately 64 grams (2.25 ounces)

Timer Dimensions (without metal housing)

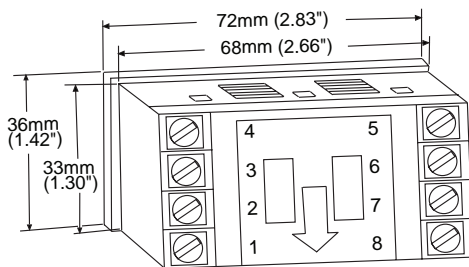

Rear Terminal Connections

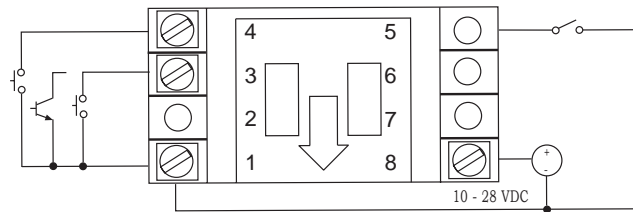

- 1. Common
- 2. Not Used
- 3. Timing Enable - NPN or dry contact inputs
- 4. Remote Reset - Resets time value when tied to common
- 5. Front Panel Program Enable - Allows access to program mode when tied to common
- 6. Not Used
- 7. Not Used
- 8. DC Supply Input - For backlighting

Timer Battery Replacement

The unit is shipped with one CR ½ AA size 3V Lithium battery, which is pre-installed.

To change the battery, remove the battery cover by pushing inward and down. Install the battery in either of the two slots. The unit runs on a single battery, and the second slot is provided to allow for installing a new battery before removing the old one, retaining count total and program data. The unit can also be run on two batteries to extend the battery life to 10 years.

Once the battery is in place the unit will go into a self test mode, and all the segments on the LCD display will be illuminated. The self test mode is exited by depressing the Next key, which will then display the model number (6). Depress the Next key again to ready the unit for operation.

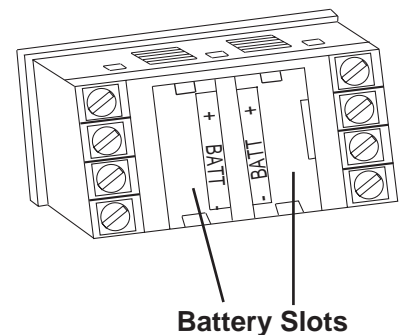

In-line Wall Carrier Mount Assembly - Single Basin Sinks (part #S0001)

This drawing shows how the in-line wall carrier for single basin scrub sinks is assembled.

NOTE: To ensure stability, MAC Medical recommends that the In-line Wall Carrier Mount Assembly be tied into the existing wall support structure. All applicable local and state building codes should be adhered to when mounting this unit.

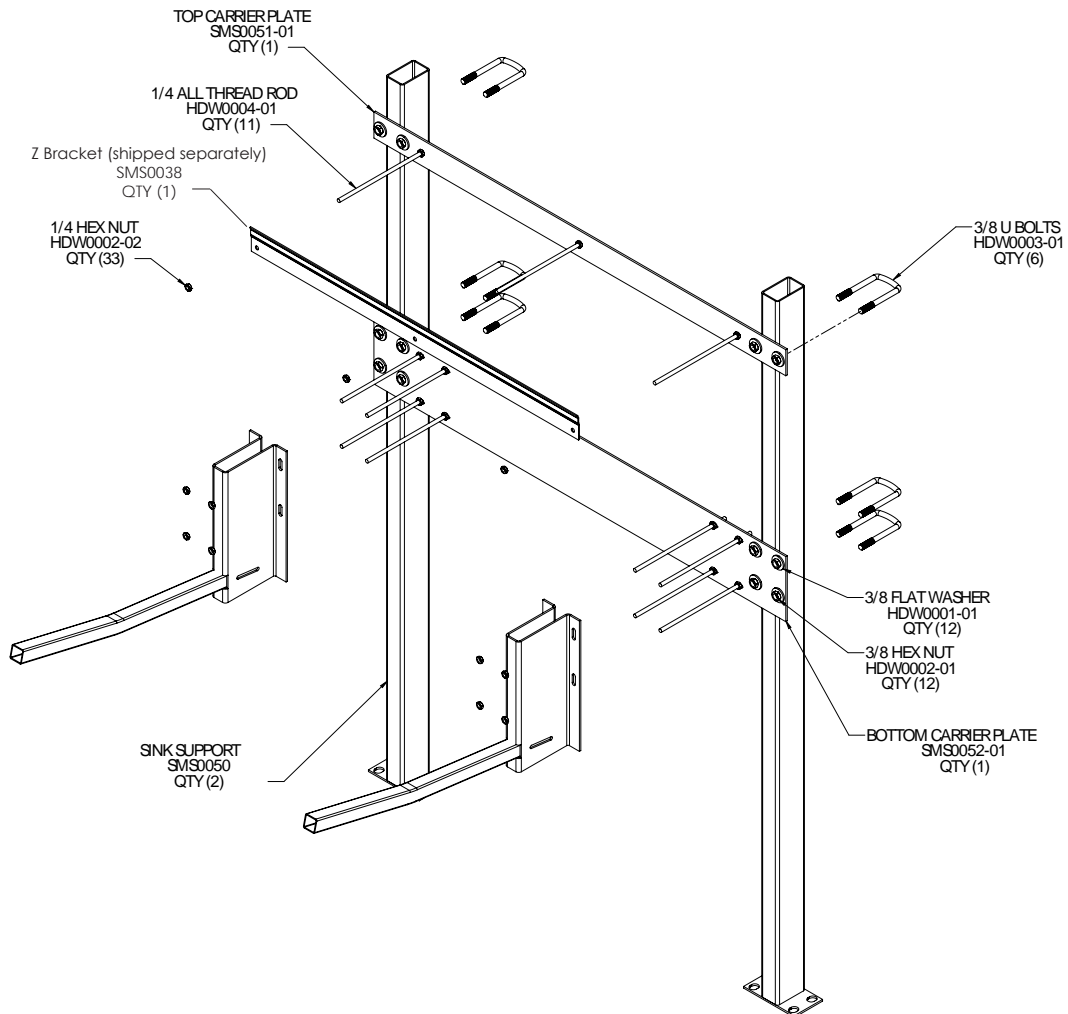

In-line Wall Carrier Mount Assembly - Dual Basin Sinks (Part #S0002)

This drawing shows how the in-line wall carrier for dual basin scrub sinks is assembled.

NOTE: To ensure stability, MAC Medical recommends that the In-line Wall Carrier Mount Assembly be tied into the existing wall support structure. All applicable local and state building codes should be adhered to when mounting this unit.

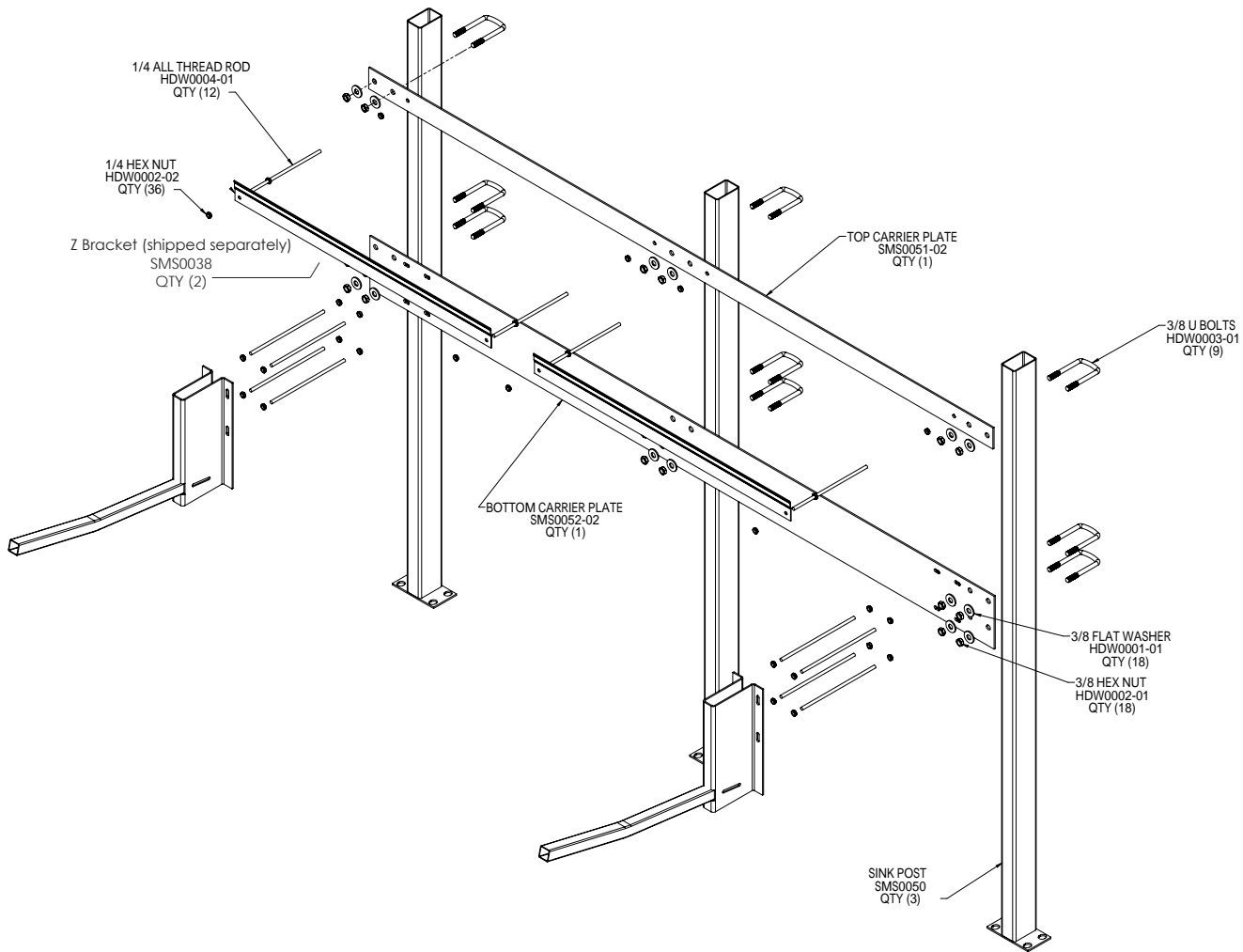

In-line Wall Carrier Mount Assembly - Triple Basin Sinks (Part #S0003)

This drawing shows how the in-line wall carrier for triple basin scrub sinks is assembled.

NOTE: To ensure stability, MAC Medical recommends that the In-line Wall Carrier Mount Assembly be tied into the existing wall support structure. All applicable local and state building codes should be adhered to when mounting this unit.

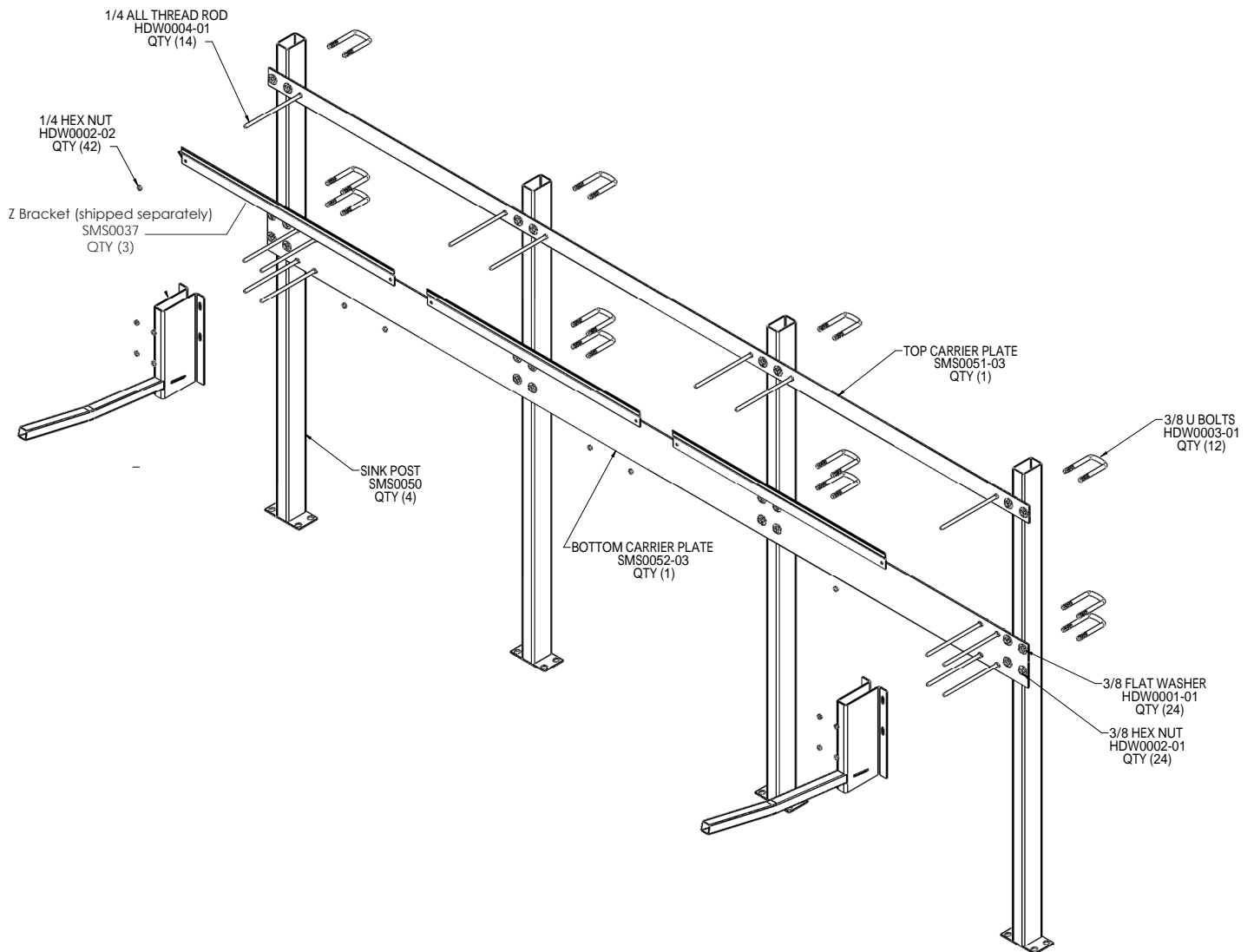

Limited Lifetime Warranty

MAC Medical warrants to the original purchaser that its Proprietary Products will be free from defects in workmanship or materials under normal use and service for the life of the product, so long as owned by the original purchaser, according to the limitations set forth below.

Defective products shall be repaired or replaced at MAC Medical's option at no cost to the original purchaser provided:

1. The customer must obtain a written return authorization supplied by MAC Medical's customer service department. The product must be returned, properly packaged, with a copy of the original sales receipt and copy of the RMA authorization. Please call (877) 828-9975 or (618) 476-3550 to receive a return authorization.
2. The customer must pre-pay freight charges to and from MAC Medical and must ship merchandise properly packaged, in a way the product will not be damaged during transit to the factory. MAC Medical does not warranty any freight damage to or from the factory. It is the customer's responsibility to inspect the product for packaging damage before signing the BOL.

This warranty does not apply to products, which have been subject to abuse, misuse, accident, modification, alteration, tampering, negligence, lack of routine maintenance or misapplication; or products that have been repaired by other than MAC Medical or its authorized representatives.

This warranty does not apply to glass, fabrics, vinyl, seat coverings, cushions, padding or their stitching, gluing or installation. Component parts not manufactured by MAC Medical, such as casters, caster inserts, any components made from rubber or plastic, circuit boards, fan heaters, plumbing parts, electrical switches and other components are also excluded. For these component parts, MAC Medical will pass on the original manufacturer's warranty to MAC Medical equipment original purchasers. Please consult factory for questions regarding the warranties of these component parts. This warranty does not apply to custom fabricated products. Consult factory.

UNLESS EXPRESSLY SET FORTH IN THIS WARRANTY, THERE ARE NO OTHER WARRANTIES, WHETHER EXPRESS OR IMPLIED, OF FITNESS AND/OR MERCHANTABILITY OR ANY OTHER WARRANTY IMPLIED BY CUSTOM, USAGE OR COURSE OF DEALING.

Liability of MAC Medical under this warranty is limited to the repair and/or replacement of any products. MAC Medical specifically excludes and disclaims any responsibility for any incidental or consequential damages claimed to have arisen from any defect in workmanship or materials. No representative has any authority to change or enlarge the above warranty or MAC Medical liability. This document supersedes all previous warranty provisions.

To place an order, contact our customer service department at **618-476-3550** or **877-828-9975** or by email at sales@macmedical.com

MADE IN THE USA



INSPIRED
TO BE BETTER

Customer needs are our first priority.

MAC Medical, Inc.
Printed in USA
Publication No. MAN-004 Rev I
August 2021

Information regarding this product is subject to change without prior notice.



Corporate Office
200 Admiral Weinel Blvd.
Columbia, Illinois 62236

Manufacturing Plant
820 South Mulberry Street
Millstadt, IL 62260

Phone: 618-476-3550 • Toll Free: 877-828-9975 • www.macmedical.com